



NIC Module Configuration Guide

9.0v1

SECURITY MANAGEMENT SYSTEM

9600-0402

© G4S Technology 2018

All rights reserved. No part of this publication may be reproduced in any form without the written permission of G4S Technology Limited.

G4S Technology Limited cannot be held liable for technical and editorial omissions or errors made herein; nor for incidental or consequential damages resulting from the furnishing, performance or use of this material.

NOTE: This equipment has been tested and found to comply with the limits for a Class A digital device, pursuant to part 15 of the FCC Rules. These limits are designed to provide reasonable protection against harmful interference when the equipment is operated in a commercial environment. This equipment generates, uses and can radiate radio frequency energy and, if not installed and used in accordance with the instruction manual, may cause harmful interference to radio communications.

Operation of this equipment in a residential area is likely to cause harmful interference. In which case, users will be required to correct the interference at their own expense.

NIC Module Configuration Guide 9600-0402

Issue 9.0v1 – 21st March 2018

Applies to version 9.0 or later of the Symmetry Software, until superseded by a later issue of the manual.

All trademarks acknowledged.

Microsoft and Windows are registered trademarks of Microsoft Corporation.

Contents

Preface	2
About this Guide	2
Chapter 1: Introduction	3
About NIC Modules	3
Supported NIC Modules	4
IP Addresses and DHCP	4
Continuous and Periodic Polling	4
Encrypted Communications	5
Dual NIC-4 LAN Communications	5
Fall-back Communications	5
Symmetry Configuration	6
Setting up a LAN Chain	6
Setting up Fall-back Communications	6
Chapter 2: Configuring a NIC Module	7
Introduction	7
Accessing COBOX.EXE	7
Pre-Configuration Tasks	7
Enabling Encrypted Communications	7
Setting up COBOX.INI	7
Using the Configuration Tool (COBOX.EXE)	8
Verifying Configuration Settings	10
Cold Starting the Module	10
Index	11

Preface

About this Guide

The *NIC Module Configuration Guide* is a reference document for the configuration of NIC modules in Symmetry Local Area Network (LAN) chains.

It is assumed that readers of this manual understand the basic concepts of security management and access control. If you do not have this knowledge, please read the introductory chapters of the *Security Management System User's Guide* first.

It is also assumed that installers are competent and understand such term as IP Address, DHCP, RS232, etc.

Note: Please refer to the appropriate *NIC Module Installation Instructions* (supplied with the module) for detailed information relating to connections, LEDs, switches and links.

This manual should be read in conjunction with the product help, which is also available in printed form as the *Symmetry Software Reference Manual*.

Chapter 1: Introduction

About NIC Modules

A NIC module allows the Symmetry software to communicate with Symmetry M2100 or M2150 nodes over a network. If two or more Symmetry nodes are connected as a LAN chain (Figure 1), the NIC module must be fitted to the first node in a chain.

There can be many different LAN chains connected to the same network. The network may be used for other purposes, such as communications between the Symmetry server and clients, or for general office network communications.

All communication between the Symmetry software and the chain is managed by a nominated Symmetry client PC. For systems that contain a large number of nodes and high-volume transaction activity, this architecture allows load balancing across multiple Symmetry client PCs.

It is allowable to have more than one LAN chain managed by the same Symmetry client PC. Depending on the license purchased, each Symmetry client can manage up to 512 LAN chains, with a system maximum of 1024.

The node address of the first node in a LAN chain must be 001.

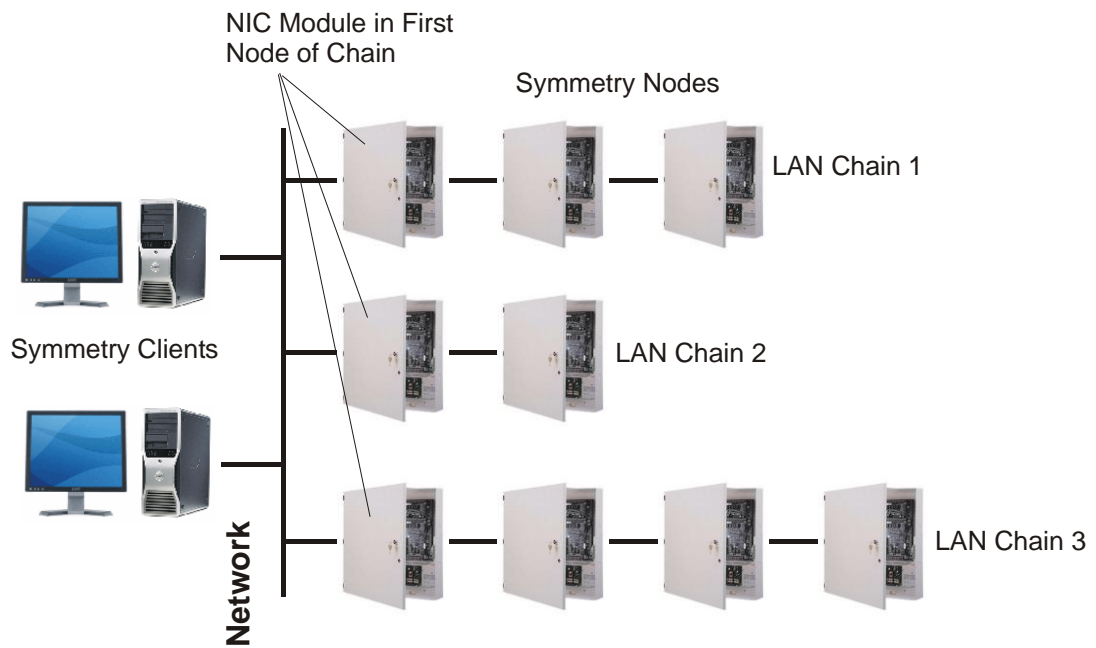

Figure 1 NIC Modules in LAN Chains

Supported NIC Modules

The following NIC modules are supported (Figure 2):

- **NIC-3** (Lantronix XPort-03). This is 10/100 MBit NIC module for the M2100 door controller range. The module supports AES encryption and DHCP-assigned IP addresses. The module has a serial port, which can be connected to a modem to provide fall-back (dial-in) communications with a Symmetry client if the network connection is lost.
- **NIC-4** (Lantronix Micro125). This is a smaller 10/100 MBit NIC module for the M2150 range of products. The module supports AES encryption and DHCP-assigned IP addresses. No serial port is provided.

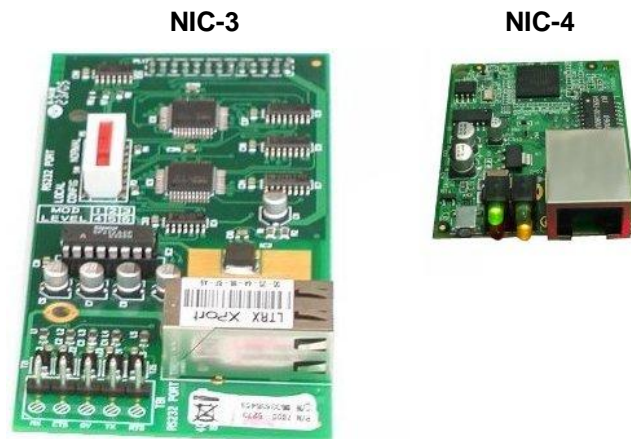

Figure 2 NIC Modules

IP Addresses and DHCP

You can use the supplied programming utility (COBOX.EXE) to specify the IP settings of the NIC module, and the IP address of the PC that the LAN chain is to communicate with. The IP address settings also need to be set up in the LAN Chain Definitions screen in the Symmetry software.

Each NIC module uses a unique IP address, which can be static or DHCP-assigned. If the address is DHCP assigned and the network also has a DNS server, Symmetry can communicate with the NIC module by name rather than by IP address.

Continuous and Periodic Polling

When setting up a LAN chain in the "Install/Access Control/Chains/LAN" screen, you can choose whether to use continuous polling or periodic polling.

Continuous polling maintains a continuous communications link from the PC that manages communications with the LAN chain.

Periodic polling causes the nominated PC to initiate communications at specified intervals and when there is new data to download (e.g. changes to card holder details). However, if a chain detects an alarm, communications are automatically initiated from the chain, and the alarm message is uploaded. Note that the "Maintenance/Access Control/Upload" screen can be used to upload event data at other non-scheduled times.

Encrypted Communications

Some high-security installations may require encrypted communications between a client and the LAN chains it manages. This can be achieved by fitting a NIC module that contains encryption firmware, which is available by special order only. NIC modules use AES encryption (the US government approved encryption standard).

It is possible for a client PC to control a mixture of encrypted and non-encrypted LAN chains.

Note: If you are setting up an encryption-enabled NIC module, you should carry out the configuration procedure on an isolated network. This is to ensure that there is no chance of the encryption key or password being intercepted by others during the programming process.

See page 7 for further information.

Dual NIC-4 LAN Communications

The M2150 range of controllers support the use of two NIC-4 modules in a single node. The secondary NIC module is used if the network connection to the primary fails. Each NIC module uses a separate IP address, but only one LAN chain needs to be defined in the Symmetry software. The main tab of the LAN Chains Definition screen is used to specify the IP address settings for the primary NIC module. A **Secondary** option enables the IP address settings to be specified for the secondary NIC module.

Please refer to the M2150 node's installation instructions for details of the DIP-switch settings that are required to enable primary/secondary LAN communications.

Fall-back Communications

A NIC-3 module has a serial port, which can be connected to a modem to provide fall-back (dial-in) communications with the Symmetry software in the event the network connection is lost (refer to the *NIC Module Installation Instructions* for connection details).

The modem can connect to a standard PSTN telephone line and is used only if the chain detects an alarm condition when network communications are unavailable.

Note that fall-back communications are disabled if the Symmetry software has been configured to expect a serial device (such as an alarm panel, defined in the "Install/System/Port Settings" screen) on the RS232 port.

Symmetry Configuration

The following provides an overview of the steps you need to take to configure LAN chains in the Symmetry software. Please refer to the *Online Help* if you require further information.

Setting up a LAN Chain

To set up a LAN chain, you need to:

1. Use the "Install/System/Client Ports" screen to specify the port on the selected client that is to manage communications with the LAN chain.
2. Set up the LAN chain using the "Install/Access Control/Chains/LAN" screen.
3. Set up each node on the chain using the "Install/Access Control/Node" screen. You must specify one of these nodes to be the first node in the chain.

Setting up Fall-back Communications

To set up fall-back communications for a LAN chain, you also need to:

1. Set up the information in the Fallback tab of the "Install/Access Control/Chains/LAN" screen.
2. Use the "Install/System/Client Ports" screen to create a port for a secondary dial-in chain.
3. Create a new record in the "Install/Access Control/Chains/Dial-Up" screen, and set the following options:

Client Name – Select the name of the client that is connected to the secondary dial-in port.

Port Name – Select the secondary dial-in port.

Host Initialization String – Select the modem type being used at the client, or enter the initialization string if a different modem is being used.

Chapter 2: Configuring a NIC Module

Introduction

Before a NIC module can be used in an M2100 or M2150 LAN chain, you must configure it using the supplied configuration tool, COBOX.EXE. Both the PC and NIC module must be on the same network.

Accessing COBOX.EXE

COBOX.EXE is located on the Symmetry server in the Symmetry installation folder (e.g. C:\Program Files\Security Management System). You can either run the tool from the server, or copy the following files to a folder on another computer and run it from that location:

- COBOX.EXE (e.g. located in C:\Program Files\Security Management System)
- SymmetryCryptographicModule.dll (e.g. located in C:\Program Files\Security Management System)
- COBOX.INI (e.g. located in C:\Program Data\Security Management System)

Pre-Configuration Tasks

Enabling Encrypted Communications

If encrypted communications is used (see page 5), an operator with Engineer privileges must use the "Install/System/Client Ports" and "Install/Access Control/Chains/LAN" screens in the Symmetry software to enable encrypted communications and to specify the encryption key, which must match the one that is programmed into the NIC module during the configuration procedure. All encryption-enabled NIC modules that are being managed by the same Symmetry client must use the same encryption key.

Setting up COBOX.INI

Before starting COBOX.EXE, check COBOX.INI as follows (see "Accessing COBOX.EXE" for location details):

For a non-encryption-enabled module, use the following settings in COBOX.INI:

```
AllowColdStart=1
DisplayEncryption=0
EnableCurrentNIC=0
```

For an encryption-enabled module, use the following settings in COBOX.INI:

```
AllowColdStart=1
DisplayEncryption=1
EnableCurrentNIC=1
```

Using the Configuration Tool (COBOX.EXE)

To configure a NIC module:

1. Ensure that the NIC module is plugged into the first node in the LAN chain and is connected to the same network as the Symmetry server PC that you are using. Apply power to the node.
2. Log in with local Administrator privileges. This is important.
3. Double-click COBOX.EXE (see "Accessing COBOX.EXE" for location details). The following window is displayed:

4. In the **Client IP Address** box (STEP 1 section), enter the IP address of the PC that is to communicate with the NIC module. The default IP address shown is that of the machine you are currently using.
5. In the STEP 2 section, click the **Find** button. This will search for all NIC modules in the network. When complete, the **NIC MAC Address** box changes into the **NIC Modules Found** combo box, which lists the address of each NIC module found in the network.

If the network has a DHCP server, a new NIC module is automatically assigned an IP address by the DHCP server. If no DHCP server exists, the NIC module gives itself a temporary APIPA address (Private address 169.x.x.x), which COBOX.EXE can discover. (The address is not stored at this point, and therefore a different address may be assigned if the device is re-powered.)

6. Select the NIC module you want to configure from the **NIC Modules Found** combo box. Addresses shown in black are in the same subnet as the PC. Addresses shown in red are in a different subnet. If you want to configure a NIC module shown in red, you will need to change the PC's network settings so that it is in the same subnet as the NIC module, and has a valid IP address for that subnet.

STEP 2 - Enter Node NIC Card and Baud Rate Information

NIC Modules Found: 00-20-4A-89-07-A5 = 192.168.2.24

Obtain IP address automatically
 DHCP Host Name: [] (Name you want to assign to the node)

Use the following IP configuration
 New NIC IP Address: [] (IP address you want to assign to the node)
 Current NIC IP Address: 192 . 168 . 2 . 24
 Subnet Mask: 255.0.0.0 (Subnet Mask you want to assign to the node)
 Gateway IP Address: [] (Leave blank if a gateway is not used)

Node Baud Rate: 19200 (Must match the baud rate set at the node)

Cancel

The code displayed indicates the module's unique MAC address, followed by its current IP address. The MAC address is printed on a label on the module.

Note: NIC Modules Found does not list encryption-enabled NIC modules that have already been configured. If you want to set up the IP address for such a device, enter its current IP address in **Current NIC IP Address**.

Note: If you search for NIC modules on a network with "live" LAN chains that include any type of NIC module, these chains will momentarily go "off-line" during the search. If this causes a problem, the NIC module should be programmed on a separate network.

7. If the IP address of the module is to be DHCP assigned, click **Display NIC Info** and check that **software version** is 6.1.0.2 or later. If it is not, download the latest firmware and upgrade instructions from the Lantronix web site (www.lantronix.com), and restart the configuration process.
8. Select the IP address settings as follows:

If the NIC module is to obtain its IP address from a DHCP server, choose **Obtain IP address automatically** and enter the network name you want to give the NIC module. This will enable the Symmetry software to communicate with the NIC module by name rather than by IP address. If you want to assign a static IP address, choose **Use the following IP configuration** and select the following:

- **New NIC IP Address** - Enter the IP address you wish to program into the selected NIC module.
 - **Subnet Mask** - This must match the subnet mask used by the managing Symmetry client PC.
 - **Gateway IP Address** - This is normally left blank (uses default gateway). If required, specify a gateway address compatible with the network.
9. In the **Node Baud Rate** field, enter the correct baud rate for the communication between the NIC module and the node in the LAN chain (as set by the DIP switches in the node).
 10. If the NIC module is encryption enabled and you want to want to use the module for encrypted communications:
 - a) Select **Encrypt** in the STEP 4 section, and click **OK** when the warning message is displayed for you to check that the NIC module supports encryption.
 - b) In the **128/256 Bit Key** field, enter 16 or 32 pairs of hexadecimal characters. This key must match the key specified in the "Install/System/Client Ports" screen in the Symmetry software.

- c) In the **16 Character Password** field, enter a password. You will need to enter the password if you need to verify, re-program or cold start the module.

The password protects the configuration port of the NIC module. All other ports will be disabled when programming has been completed.

11. You are now ready to program the settings into the selected NIC module. In the STEP 3 section, click the **Program** button.

If you are setting up an encryption-enabled NIC module, you are warned to carry out the encryption procedure on an isolated network.

Confirmation of the information programmed into the module is displayed in the **Information** window. Once programmed, the utility will re-query the network for the updated NIC module.

Verifying Configuration Settings

If you want to view the settings of a NIC module that is already configured:

1. Click the **Display NIC Info.** button. The programmed parameters are displayed in the **Information** window.

Once programmed, an encryption-enabled module will indicate that it can be encrypted by the display of the “encryption capability detected” line in the Information window:

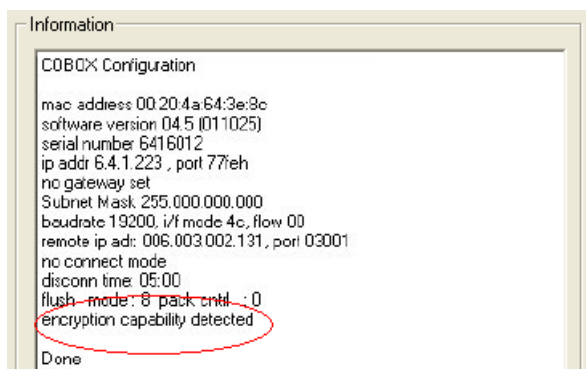

2. To verify communications to the node, click the **Check Node OK** button. When communicating with an encryption-enabled NIC module, the encryption key specified in the COBOX.EXE dialog must match the key currently programmed into the module.

The result is also displayed in the **Information** window.

Cold Starting the Module

If required, you can return a NIC module back to factory settings by selecting it the module in the NIC Modules Found list and clicking **ColdStart** (requires AllowColdStart to be set to "1" in the COBOX.INI file; see page 7).

Cold starting an encryption-enabled module removes the IP address, encryption key and password.

Index

COBOX.EXE, 7
COBOX.INI, 7
Cold starting, 10
Configuration
 procedure, 7
 viewing, 10
DHCP, 4, 9
Dual NIC-4, 5
Encrypted communications, 5, 7

Fall-back communications, 5
IP address, 4, 9
LAN Chain, 3
NIC module overview, 3
NIC-3 and NIC-4 overview, 4
Node address, 3
Polling (continuous and periodic), 4
Primary/secondary communications, 5